



NMRA Standard	
Power Station Interface	
Jun 9, 2021	S-9.1.2

1 General

1.1 Introduction and Intended Use (Informative)

5 The purpose of this Standard is to define communication between Command Stations and Power Stations to facilitate the basic interchange of DCC equipment produced by various manufacturers. It is applicable when Command Stations or Power Stations are tested for conformance independently of each other. It is also applicable when conformance testing an integrated DCC System, which includes both Power Station Interface and Power Station outputs. It is not applicable when conformance testing a DCC system which includes only a Power Station output but no Power Station Interface output.

10 The main goals are as follows:

1. Define the electrical characteristics of the interface.
2. Define limits on the amount of distortion that each component can introduce to the DCC signal measured at the track.
3. Define the transmission medium of the interface.
- 15 4. Define the allowable physical topology of the interface.
5. Define the labeling of various components and connections.

1.2 References

This standard should be interpreted in the context of the following NMRA Standards, Technical Notes, and Technical Information.

20 1.2.1 Normative

- S-9.1 Electrical Standards for Digital Command Control, which specifies DCC bit timing and track voltage.
- S-9.2.4 Fail-Safe Operating Characteristics for Digital Command Control, which specifies how system components interact under adverse conditions.
- 25 • S-9.3.2 DCC Basic Decoder Transmission, which defines communication from a DCC decoder to a track circuit based detector.

1.2.2 Informative

- TN-9.1.2 Power Station Interface, which provides commentary on the Power Station Interface Standard.
- 30 • RCN-210 DCC Protocol Bit Transmission, with which S-9.1 is intended to be in harmony.ⁱ
- RCN-217 DCC Feedback Protocol (RailCom¹), with which S-9.3.2 is intended to be in harmony.ⁱ
- NEM 670 Digital Command Control Signal DCC Bit Representation, with which S-9.1 is intended to be in harmony.ⁱⁱ
- 35 • Electrical Characteristics of Balanced Voltage Digital Interface Circuits, ANSI TIA/EIA 422 Standard.ⁱⁱⁱ

¹ RailCom[®] is a registered trademark of Lenz Elektronik GmbH.

- Electrical Characteristics of Generators and Receivers for Use in Balanced Digital Multipoint Systems, ANSI TIA/EIA-485 Standard.ⁱⁱⁱ

1.3 Terminology

Term	Definition
Bipolar Signal	An electrical signal that carries information having equal voltage components above and below 0 volts. In the context of the NMRA DCC standard, this signal will have a positive half-cycle and a negative half-cycle. (+ volts and - volts respectively)
Power Station Feedback	A means of transmitting information from a Power Station to a Command Station.
DCC Positive Polarity	The wire or rail which has a positive voltage for the first half-cycle of the DCC bit.
Command Station	The DCC system component whose purpose is to generate and source a stream of DCC bit data to the Power Station Interface.
Power Station	A device that amplifies the low current DCC electrical signals transmitted by a Command Station for the purpose of providing high current DCC signals with sufficient power to operate model trains and any accessory decoders that are connected to the track. Also known as booster or power booster.
Power Station Interface	The communications medium (“wires”) which connects a Command Station’s signal generator to one or more Power Stations.
Power Station Interface Repeater	A device that amplifies the Power Station Interface signal to allow additional capacity for more Power Stations to be connected.
Power Station Interface Segment	The singular Power Station Interface path between a Command Station and a given Power Station.
TIA/EIA-422	ANSI differential signal standard commonly known as RS-422.
TIA/EIA-485	ANSI differential signal standard commonly known as RS-485.
AWG	American Wire Gauge. A logarithmic stepped standardized wire gauge system used since 1857, predominantly in North America.

40 1.4 Requirements

To meet this Standard, all electrical values and labeling requirements shall be met and respected, unless otherwise noted. It is not necessary to implement both the Full Scale Interface and Driver/Receiver Interface options. Only one of these interface options is required.

45 This Standard is required for all new products introduced after January 1st 2022. This Standard is optional for all products introduced before January 1st 2022. Exemptions may be granted at the discretion of the NMRA Conformance and Inspection department. Exemptions granted shall be noted in the product documentation and reviewed for accuracy by the NMRA Conformance and Inspection department.

2 Electrical Characteristics

50 The Power Station Interface specifications are divided into two types:

1. Full Scale Interface
2. Driver/Receiver Interface

55 Command Station / Power Station combinations following one of these interface types may interchange with devices of the same type. There is no exclusion of interchange between the two types as long as the product manufacturer documents the interchange.

2.1 Common Characteristics

2.1.1 Command Station (signal generator) Output Signal

The Power Station Interface signal output by the Command Station described in this Standard shall conform to the timing specifications described in the NMRA DCC Standard S-9.1.

60 When a Command Station is not powered, or when its Power Station Interface output is disabled, it shall ensure that the two output signals do not have a floating voltage potential with respect to one another.

The Power Station Interface signal is specifically designed as bipolar.

2.1.2 Power Station Input to Output Distortion

65 Other than for the purpose of producing a basic decoder transmission cutout, as described in S-9.3.2, a Power Station shall not alter the signal from its Power Station Interface input to its track output terminals outside an allowed signal propagation delay and distortion within the range in Table 1 below.

Table 1: Power Station Distortion Limits

T_{on}	Less than or equal to 5 microseconds
T_{off}	Less than or equal to 5 microseconds
$ABS(T_{off} - T_{on})$	Less than or equal to 2 microseconds

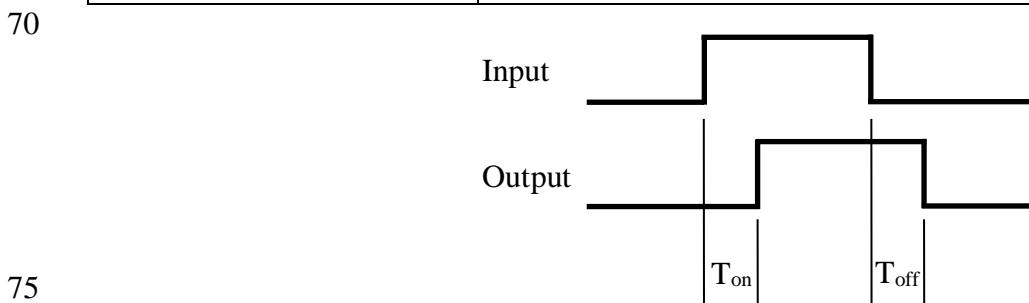

Figure 1: Power Station Distortion

2.1.3 Power Station Input to Output Distortion

Interface Repeater

80 A Power Station Interface Repeater amplifies the Power Station Interface signals so that additional power stations can be supported. Only a single repeater may be used on any Power Station Interface Segment. On input, the repeater has the same requirements as a Power Station. On output, the repeater has the same signal level requirements as a Command station and timing requirements as a

Power Station except that the total allowed signal propagation delay and distortion is reduced as defined in Table 2 below.

85 **Table 2: Power Station Repeater Distortion Limits**

T_{on}	Less than or equal to 1 microseconds
T_{off}	Less than or equal to 1 microseconds
ABS (T_{off} – T_{on})	Less than or equal to 0.5 microseconds

2.1.4 Power Station Common

Power Stations without electrically isolated interface inputs shall provide the ability to connect the common side of their DC power supplies together. Instructions on the use of the Power Station Common shall be provided in the product documentation.

90 **2.1.5 Power Station Fail-Safe**

In order to avoid a decoder conversion to an alternate power source, as described in S-9.2.4, Power Stations shall disable their output when a valid DCC packet is not received for more than 30 milliseconds on the Power Station Interface. If a power station is designed for multiple protocol use, this requirement may be disabled, or have a different duration set, through a configuration option. If this requirement can be disabled through configuration, it shall be noted in the product documentation.

2.2 Full Scale Interface

The term Full Scale is derived from the voltage levels of this interface being designed to match the standard track voltage levels defined in S-9.1.

100 **2.2.1 Command Station Output Signal**

A bipolar signal shall appear differentially on a two-wire interface with a signal amplitude of no less $\pm 8.5V$ and no greater than $\pm 24V$. The Command Station output shall be capable of supplying $\pm 8.5V$ into a 100Ω resistive load, so that multiple Power Stations may be connected to this output.

105 The output current shall be limited to no greater than 1A to reduce hazards in case of a short circuit in the Power Station Interface. The output shall be protected to prevent damage to internal devices when a short is present at the output.

Table 3: Summary of Requirement Values

Command Station Output Voltage Max	$\pm 24V$ (open circuit)
Command Station Output Voltage Min	$\pm 8.5V$ (100Ω resistive load)
Command Station Output Current Limit	1A

2.2.1.1 Test Criteria

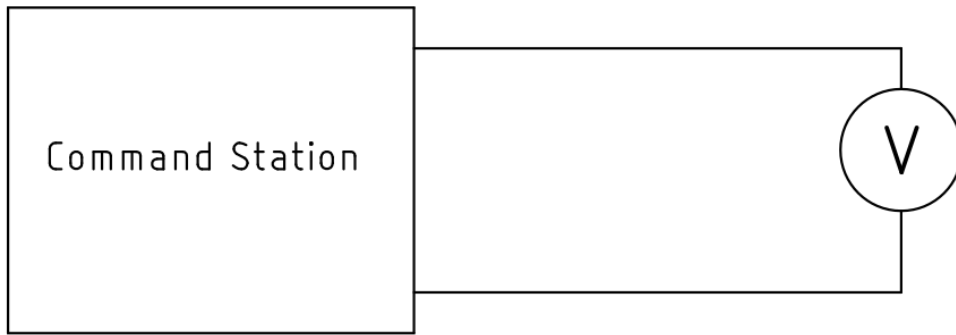

110

Figure 2: Open Circuit Test

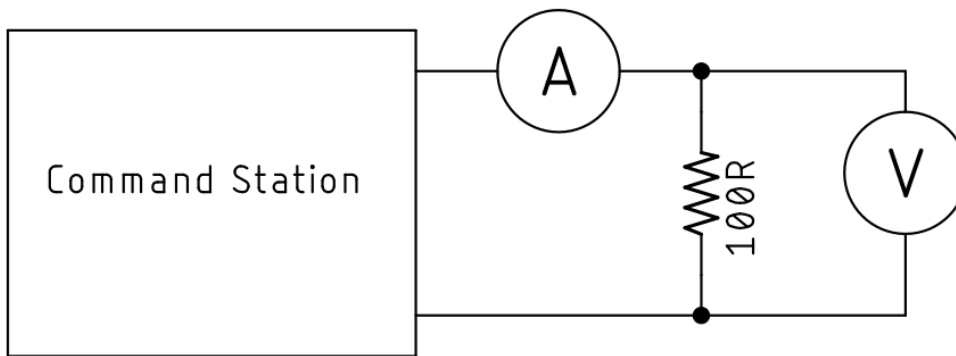
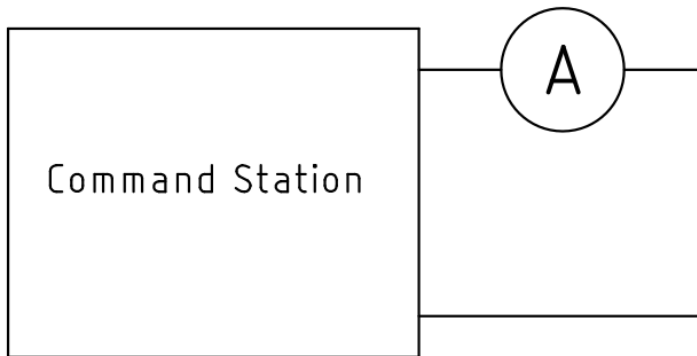

Figure 3: 100Ω Resistive Load Test



115

Figure 4: Short Circuit Test

2.2.2 Power Station Input Signal

The Power Station shall accept as a valid input a bipolar signal with an amplitude of at least $\pm 7V$ and shall be capable of accepting signals with an amplitude of up to $\pm 27V$ without damage. A Power Station may reject signals of less than $\pm 7V$, but is not required to do so. A Power Station shall reject signals of less than $\pm 1.5V$ to prevent noise or other superimposed signals from being mistakenly interpreted by the Power Station.

120

125 So that multiple Power Stations may be operated by parallel connection to the same Command Station output, the Power Station shall draw no more than 25mA from its input terminals when the input signal has an amplitude of $\pm 10V$.

130 Because the signal is bipolar, no particular relationship of either part of the signal to a ground reference may be inferred. Power Stations shall interpret the signal at their inputs as differential in nature and shall not require any explicit or implied third connection as a reference. The Power Station shall operate in the presence of common mode voltages up to $\pm 24V$ between the Command Station's internal reference and that of the Power Station.

Table 4: Summary of Requirement Values

Power Station Input Voltage Max	$\pm 27V$
Power Station Input Voltage Min	$\pm 7V$
Power Station Input Voltage Rejection Limit	$\pm 1.5V$
Power Station Input Load Current Limit	25mA at $\pm 10V$

2.2.2.1 Test Criteria

135 The circuit in Figure 5 below shall be used with the Command Station (Test Harness) output voltages of $\pm 7V$, $\pm 10V$, and $\pm 27V$. The Power Station load current limit shall only be evaluated at $\pm 10V$.

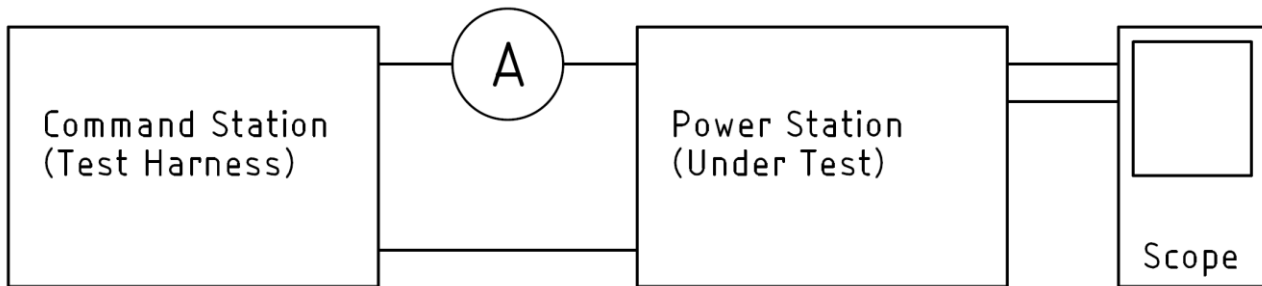

Figure 5: Power Station Input Signal Test

2.3 Driver/Receiver Interface

140 The Driver/Receiver Interface type is characterized by the Command Station output connected to the Power Station input using a differential TIA/EIA-422 or TIA/EIA-485 driver/receiver pair. This interface also carries a ground signal which the differential signals shall be referenced to. TIA/EIA-422 and TIA/EIA-485 driver/receiver standards have overlapping operating ranges and are commonly used together and/or interchangeably.

145 The NMRA Conformance and Inspection department shall work with the manufacturer to determine conformance through design inspection. Conformance requires that industry standard TIA/EIA-422 or TIA/EIA-485 components are used.

2.3.1 Command Station Output Signal (TIA/EIA-422)

150 A bipolar signal shall appear differentially on a two-wire interface with a signal amplitude of no less than $\pm 2V$ and no greater than $\pm 10V$. The Command Station output shall be capable of supplying $\pm 2V$ into a 100Ω resistive load.

The output current of each differential signal shall be limited to no greater than 150mA when shorted to the reference ground to reduce hazards in case of a short circuit in the Power Station Interface.

These specs are intentionally designed around the TIA/EIA-422 standard.

155 **Table 5: Summary of Requirement Values**

Command Station Output Differential Voltage Max	±10V (open circuit)
Command Station Output Differential Voltage Min	±2V (100Ω load)
Command Station Output Short Circuit to Ground Current Limit	150mA

2.3.2 Command Station Output Signal (TIA/EIA-485)

A bipolar signal shall appear differentially on a two-wire interface with a signal amplitude of no less than ±1.5V and no greater than ±5V. The Command Station output shall be capable of supplying ±1.5V into a 60Ω resistive load.

160 The output current of each differential signal shall be limited to no greater than 250mA when shorted to -7V or +12V to reduce hazards in case of a short circuit in the Power Station Interface.

These specs are intentionally designed around the TIA/EIA-485 standard.

Table 6: Summary of Requirement Values

Command Station Output Differential Voltage Max	±5V (open circuit)
Command Station Output Differential Voltage Min	±1.5V (60Ω load)
Command Station Output Short to -7V or +12V	250mA

2.3.3 Power Station Input Signal (TIA/EIA-422)

165 The Power Station shall accept as a valid input a bipolar signal with an amplitude of at least ±200mV.

So that multiple Power Stations may be operated by parallel connection to the same Command Station output, the Power Station shall have a receiver input resistance of 4KΩ or greater.

170 To account for common mode noise and differences in reference ground potential between the Command Station and Power Station, the Power Station shall operate in the presence of common mode voltages up to ±7V relative to the Power Station's reference ground input.

Table 7: Summary of Requirement Values

Power Station Common Mode Voltage Max	±7V
Power Station Input Differential Voltage Min	±200mV
Power Station Input Resistance Min	4KΩ

2.3.4 Power Station Input Signal (TIA/EIA-485)

175 The Power Station shall accept as a valid input a bipolar signal with an amplitude of at least ±200mV.

So that multiple Power Stations may be operated by parallel connection to the same Command Station output, the Power Station shall have a receiver input resistance of 12KΩ or greater.

180 To account for common mode noise and differences in reference ground potential between the Command Station and Power Station, the Power Station shall operate in the presence of common mode voltages between -7V to + 12V relative to the Power Station's reference ground input.

Table 8: Summary of Requirement Values

Power Station Common Mode Voltage Max	-7V to +12V
Power Station Input Differential Voltage Min	±200mV
Power Station Input Resistance Min	12KΩ

3 Physical Medium

185 The cable used for transmitting the signal from the Command Station signal generator to the Power Stations shall be a single pair of wires and may utilize, twisted pair, coaxial, or any other wiring method. The minimum wire size shall be 26AWG. Other power and/or signal wires may also be bundled in the same cable as the Power Station Interface.

Additionally, the Driver/Receiver interface option shall carry a reference ground signal.

The Power Station Interface shall not require special termination.

190 The Power Station Interface and/or additional wires may optionally provide for feedback from the Power Station to the Command Station. Manufacturers that utilize feedback are encouraged to provide their specifications to the NMRA for possible future standardization.

4 Topology

195 Only one Command Station signal generator output or Power Station Interface Repeater output may be connected to a Power Station Interface. Inputs of many Power Stations may be connected in parallel connection to the two wires of the Power Station Interface. It is acceptable to use tree, star, and daisy chain connections. However, it is not allowed to connect any part of the Power Station Interface in a loop. The Power Station Interface branches shall not create a loop to themselves or to another branch.

5 Labeling

200 The Command Station, Power Station, or Repeater shall be directly labeled and/or provide accompanying documentation to indicate the following properties:

1. Interface type used (Full Scale or Driver/Receiver).
2. Power Station Interface output current capacity or limit (Command Station and Repeater only).
- 205 3. Power Station Interface input loading (Power Station and Repeater only).
4. Receiver input resistance in the case of Driver/Receiver Interface
5. Which terminals carry the positive and negative polarity signals. If terminals are labeled A and B, A shall correspond to the positive polarity and B shall correspond to the negative polarity.²
- 210 6. Power Station Common (only required if Power Station input is not electrically isolated).
7. If the Power Station Interface on a Power Station is electrically isolated, it shall be noted.

² Power Stations with integrated auto-reversing will violate this requirement as an intentional feature when enabled, and therefore are exempt whenever auto-reversing is enabled.

6 Document History

Date	Description
2003	First Revision
Jun 9, 2021	Updates to fix missing and incorrect information.

ⁱ RCN stands for RailCommunity Normen. The direct German to English translation of Normen is Norms, and in this context is intended to have an equivalent meaning to Standards. RailCommunity is an organization of manufacturers that creates German language standards for model railway electronics.

ⁱⁱ NEM stands for Norms of the European Model Railroads. Norms, in this context, is intended to have an equivalent meaning to Standards. MOROP is the organization that maintains the NEM documents. MOROP is an organization that creates model railway standards primarily targeted at the European market.

ⁱⁱⁱ ANSI stands for American National Standards Institute. TIA/EIA stands for Telecommunications Industry Association/Electrical Industries Association.

Important Notices and Disclaimers Concerning NMRA Standards Documents

The Standards (S), Recommended Practices (RP), Technical Note (TN), and Technical Information (TI) documents of the National Model Railroad Association ("NMRA Standards documents") are made available for use subject to important notices and legal disclaimers. These notices and disclaimers, or a reference to this page, appear in all standards and may be found under the heading "Important Notices and Disclaimers Concerning NMRA Standards Documents."

Notice and Disclaimer of Liability Concerning the Use of NMRA Standards Documents

NMRA Standards documents are developed within the Standards and Conformance Department of the NMRA in association with certain Working Groups, members, and representatives of manufacturers and sellers. NMRA develops its standards through a consensus development process, which brings together volunteers representing varied viewpoints and interests to achieve the final product. NMRA Standards documents are developed by volunteers with modeling, railroading, engineering, and industry-based expertise. Volunteers are not necessarily members of NMRA, and participate without compensation from NMRA.

NMRA does not warrant or represent the accuracy or completeness of the material contained in NMRA Standards documents, and expressly disclaims all warranties (express, implied and statutory) not included in this or any other document relating to the standard or recommended practice, including, but not limited to, the warranties of: merchantability; fitness for a particular purpose; non-infringement; and quality, accuracy, effectiveness, currency, or completeness of material. In addition, NMRA disclaims any and all conditions relating to results and workmanlike effort. In addition, NMRA does not warrant or represent that the use of the material contained in NMRA Standards documents is free from patent infringement. NMRA Standards documents are supplied "AS IS" and "WITH ALL FAULTS."

Use of NMRA Standards documents is wholly voluntary. The existence of an NMRA Standard or Recommended Practice does not imply that there are no other ways to produce, test, measure, purchase, market, or provide other goods and services related to the scope of the NMRA Standards documents. Furthermore, the viewpoint expressed at the time that NMRA approves or issues a Standard or Recommended Practice is subject to change brought about through developments in the state of the art and comments received from users of NMRA Standards document.

In publishing and making its standards available, NMRA is not suggesting or rendering professional or other services for, or on behalf of, any person or entity, nor is NMRA undertaking to perform any duty owed by any other person or entity to another. Any person utilizing any NMRA Standards document, should rely upon their own independent judgment in the exercise of reasonable care in any given circumstances or, as appropriate, seek the advice of a competent professional in determining the appropriateness of a given NMRA Standards documents.

IN NO EVENT SHALL NMRA BE LIABLE FOR ANY DIRECT, INDIRECT, INCIDENTAL, SPECIAL, EXEMPLARY, OR CONSEQUENTIAL DAMAGES (INCLUDING, BUT NOT LIMITED TO: THE NEED TO PROCURE SUBSTITUTE GOODS OR SERVICES; LOSS OF USE, DATA, OR PROFITS; OR BUSINESS INTERRUPTION) HOWEVER CAUSED AND ON ANY THEORY OF LIABILITY, WHETHER IN CONTRACT, STRICT LIABILITY, OR TORT (INCLUDING NEGLIGENCE OR OTHERWISE) ARISING IN ANY WAY OUT OF THE PUBLICATION, USE OF, OR RELIANCE UPON ANY STANDARD OR RECOMMENDED PRACTICE, EVEN IF ADVISED OF THE POSSIBILITY OF SUCH DAMAGE AND REGARDLESS OF WHETHER SUCH DAMAGE WAS FORESEEABLE.

Translations

NMRA's development of NMRA Standards documents involves the review of documents in English only. In the event that an NMRA Standards document is translated, only the English version published by NMRA is the approved NMRA Standards document.

Official Statements

A statement, written or oral, that is not processed in accordance with NMRA policies for distribution of NMRA communications, or approved by the Board of Directors, an officer or committee chairperson, shall not be considered or inferred to be the official position of NMRA or any of its committees and shall not be considered to be, nor be relied upon as, a formal position of NMRA.

Comments on Standards

Comments for revision of NMRA Standards documents are welcome from any interested party, regardless of membership. However, **NMRA does not provide interpretations, consulting information, or advice pertaining to NMRA Standards documents.**

Suggestions for changes in documents should be in the form of a proposed change of text, together with appropriate supporting comments. Since NMRA standards represent a consensus of concerned interests, it is important that any responses to comments and questions also receive the concurrence of a balance of interests. For this reason, NMRA, its departments, Working Groups or committees cannot provide an instant response to comments, or questions except in those cases where the matter has previously been addressed. For the same reason, NMRA does not respond to interpretation requests. Any person who would like to participate in evaluating comments or in revisions to NMRA Standards documents may request participation in the relevant NMRA working group.

Laws & Regulations

Users of NMRA Standards documents should consult all applicable laws and regulations. Compliance with the provisions of any NMRA Standards document does not constitute compliance to any applicable regulatory requirements. Implementers of the standard are responsible for observing or referring to the applicable regulatory requirements. NMRA does not, by the publication of NMRA Standards documents, intend to urge action that is not in compliance with applicable laws, and NMRA Standards documents may not be construed as doing so.

Copyrights

NMRA Standards documents are copyrighted by NMRA under US and international copyright laws. They are made available by NMRA and are adopted for a wide variety of both public and private uses. These include both use, by reference, in laws and regulations, and use in private self-regulation, standardization, and the promotion of modeling, structural and engineering practices and methods. By making NMRA Standards documents available for use and adoption by public authorities and private users, NMRA does not waive any rights in copyright to the NMRA Standards documents.

IMPORTANT NOTICE

NMRA Standards documents do not guarantee or ensure safety, security, health, or environmental protection, or ensure against interference with or from other systems, devices or networks. NMRA Standards documents development activities consider research and information presented to the standards development group in developing any safety recommendations. Other information about safety practices, changes in technology or technology implementation, or impact by peripheral systems also may be pertinent to safety considerations during implementation of the standard. Implementers and users of NMRA Standards documents are responsible for determining and complying with all appropriate safety, security, environmental, health, and interference protection practices and all applicable laws and regulations.